



Heat. Fan. Light



Designed, engineered and made in Australia



call 1300 727 421 or visit [www.sampfordixl.com.au](http://www.sampfordixl.com.au)



5  
Year

in-home  
warranty on unit.

2  
Year

warranty on heat lamps  
and in-line exhaust.

### Tastic® Neo Single

Remote Control

**31211 White 31212 Silver**

- Halo Heat Technology – 1 x 800 W tungsten halogen infrared heat lamp
- Omni Lighting – 3 x 9 W gimbal-mounted CFL downlights
- Ventair In-Line Extraction – ducted exhaust fan
- Remote operation of all Tastic® Neo functions
- Suits ensuites and mid sized bathrooms with ceiling height to 2.4m
- Back Draught Flaps
- External Grill supplied



5  
Year

in-home  
warranty on unit.

2  
Year

warranty on heat lamps  
and in-line exhaust.

### Tastic® Neo Dual

Remote Control

**32211 White 32212 Silver**

- Halo Heat Technology – 2 x 800 W tungsten halogen infrared heat lamps
- Omni Lighting – 3 x 9 W gimbal-mounted CFL downlights
- Ventair In-Line Extraction – ducted exhaust fan
- Remote operation of all Tastic® Neo functions
- Suits mid sized and large bathrooms with ceiling height to 3.3m
- Back Draught Flaps
- External Grill supplied



5  
Year

in-home  
warranty on unit.

2  
Year

warranty on heat lamps  
and in-line exhaust.

### Tastic® Neo Single

Hardwired

**31111 White 31112 Silver**

- Halo Heat Technology – 1 x 800 W tungsten halogen infrared heat lamp
- Omni Lighting – 3 x 9 W gimbal-mounted CFL downlights
- Ventair In-Line Extraction – ducted exhaust fan
- Suits ensuites and mid sized bathrooms with ceiling height to 2.4m
- Back Draught Flaps
- External Grill supplied



5  
Year

in-home  
warranty on unit.

2  
Year

warranty on heat lamps  
and in-line exhaust.

### Tastic® Neo Dual

Hardwired

**32111 White 32112 Silver**

- Halo Heat Technology – 2 x 800 W tungsten halogen infrared heat lamps
- Omni Lighting – 3 x 9 W gimbal-mounted CFL downlights
- Ventair In-Line Extraction – ducted exhaust fan
- Suits mid sized and large bathrooms with ceiling height to 3.3m
- Back Draught Flaps
- External Grill supplied

	Model Number	Halo Heat Technology	Remote Operation	Wall Switch	Cut Out Size (mm)	Current Rating (Amps)	Watts (Fan in Brackets)**
<b>NEO SINGLE - WHITE</b> Remote	31211	1 x 800 W Tungsten halogen	Yes	N/A	326 x 462	3.5	840 (40)
<b>NEO SINGLE - SILVER</b> Remote	31212	1 x 800 W Tungsten halogen	Yes	N/A	326 x 462	3.5	840 (40)
<b>NEO DUAL - WHITE</b> Remote	32211	2 x 800 W Tungsten halogen	Yes	N/A	326 x 712	6.8	1640 (40)
<b>NEO DUAL - SILVER</b> Remote	32212	2 x 800 W Tungsten halogen	Yes	N/A	326 x 712	6.8	1640 (40)
<b>NEO SINGLE - WHITE</b> Hardwired	31111	1 x 800 W Tungsten halogen	No	Supplied	326 x 462	3.5	840 (40)
<b>NEO SINGLE - SILVER</b> Hardwired	31112	1 x 800 W Tungsten halogen	No	Supplied	326 x 462	3.5	840 (40)
<b>NEO DUAL - WHITE</b> Hardwired	32111	2 x 800 W Tungsten halogen	No	Supplied	326 x 712	6.8	1640 (40)
<b>NEO DUAL - SILVER</b> Hardwired	32112	2 x 800 W Tungsten halogen	No	Supplied	326 x 712	6.8	1640 (40)

NB: All Tastic products are designed and approved for use in horizontal applications only. See instructions for full details. \*\*Maximum running wattage due to CFLs switching off when the heat lamps are in use.

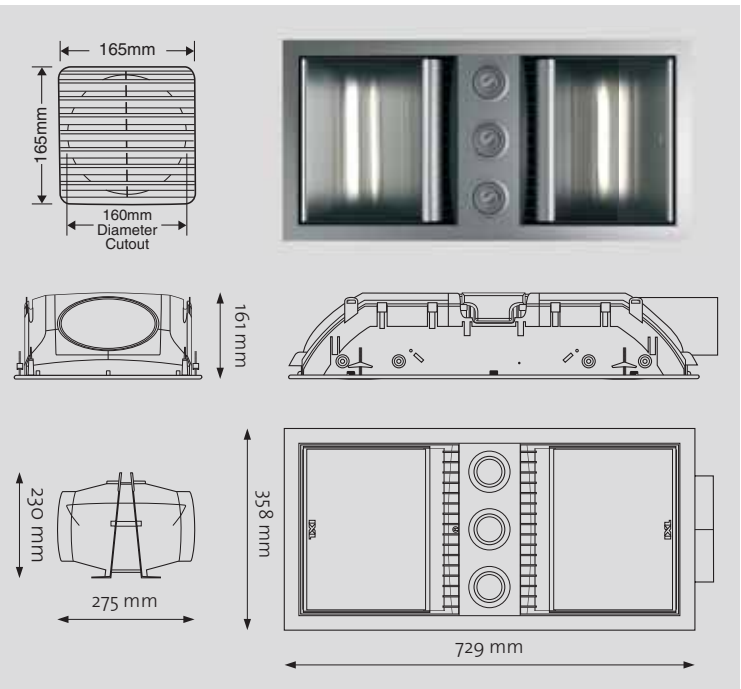
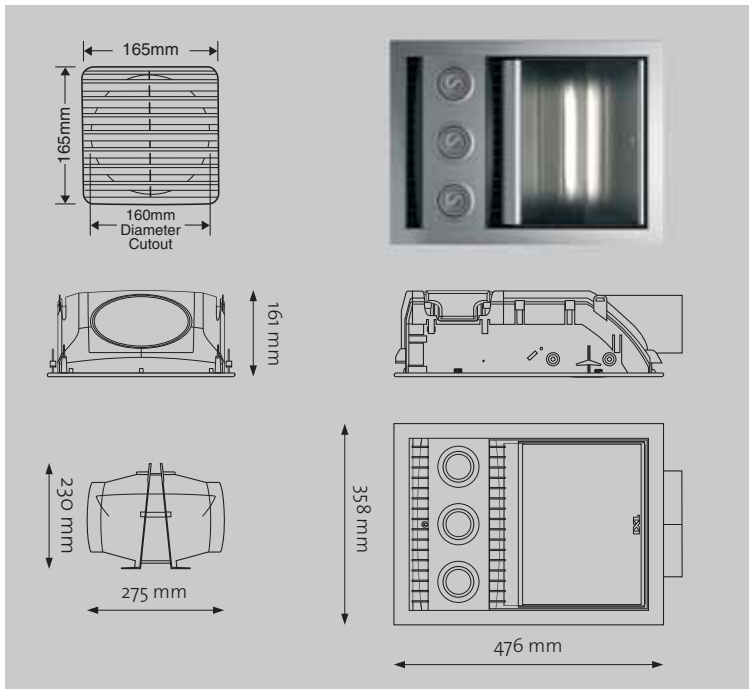

Min Clearance Above Unit (mm)	Supply (Volts)	Per Hour Cost (Cents) †	Fan Size (230 mm high) (mm)	Capacity (Litres/Sec)	Approx. Weight (kg)^	Unit Dimensions (mm)
15	240	12.6	170 ducted blower	55 (when using 6m of ducting)	5	358 (W) x 476 (L) x 161 (D)
15	240	12.6	170 ducted blower	55 (when using 6m of ducting)	5	358 (W) x 476 (L) x 161 (D)
15	240	24.6	170 ducted blower	55 (when using 6m of ducting)	9	358 (W) x 729 (L) x 161 (D)
15	240	24.6	170 ducted blower	55 (when using 6m of ducting)	9	358 (W) x 729 (L) x 161 (D)
15	240	12.6	170 ducted blower	55 (when using 6m of ducting)	5	358 (W) x 476 (L) x 161 (D)
15	240	12.6	170 ducted blower	55 (when using 6m of ducting)	5	358 (W) x 476 (L) x 161 (D)
15	240	24.6	170 ducted blower	55 (when using 6m of ducting)	9	358 (W) x 729 (L) x 161 (D)
15	240	24.6	170 ducted blower	55 (when using 6m of ducting)	9	358 (W) x 729 (L) x 161 (D)

† Based on 15c per kW/hr. Check with your local electricity provider for individual tariffs. ^ Does not include the weight of the in-line fan or the ducting.

## Tastic® Neo



The IXL Tastic® Neo lights the way for the next generation of bathroom heat, fan and light. Proudly designed, engineered and made in Australia, the Tastic® Neo is accompanied by a 5 year in home warranty, a 2 year warranty on the heat lamps and provides unsurpassed safety and quality.

**Sampford** | **IXL**

**SAMPFORD IXL PTY LTD**

421 Smith Street,  
Fitzroy, Victoria 3065  
Telephone: 1300 727 421  
Fax: 1300 727 425

**Email: [sales@sampfordixl.com.au](mailto:sales@sampfordixl.com.au)**  
**[www.sampfordixl.com.au](http://www.sampfordixl.com.au)**



5 year in-home  
warranty on unit.



2 year warranty on heat  
lamps and in-line exhaust.

Sampford IXL would like to extend a warm thank you to Tom Burke of Tom Burke Constructions for giving the Neo's pictured here a comfortable, modern and beautiful home.

Tom Burke Constructions - 0419 520665

Whilst every effort was made to provide current information at the time this brochure was produced, continuing product improvements mean the enclosed specifications, images and literature may differ from what is actually available.

